

### FEATURES

- Rugged cast aluminum housing with 3/4" wiring hubs and versatile mounting capabilities: Surface mount over recessed boxes; Quick mount wet location box; Adjustable trunnion mount; Pendant mount
- 100,000hr lamp life
- Compact 10" sq. GFO40 or 14" sq. GFP80
- Stainless steel screw closure with aircraft cable lens retainer
- Polycarbonate refractor is prismatic
- Reflector is high gloss white to maximize the lamp lumens into the refractor
- Wattages range from 26w CFL to 150w PSMH, including energy-saving induction @ 70w and 100w
- Standard finishes include dark bronze, black, white and platinum
- GFP80 are listed to UL1598 for use in wet locations

### ORDERING INFORMATION

SERIES	WATTAGE/SOURCE	VOLTAGE <sup>2</sup>	FINISH	OPTIONS
<b>GFO40</b> GFO40 Series	<b>GFO40</b>	<b>120</b> 120V	<b>DB</b> Dark Bronze	<b>C43</b> Cast junction box
<b>GFP80</b> GFP80 Series	<b>70HPS</b> 70w HPS, medium base	<b>277</b> 277V	<b>BLK</b> Black	<b>TP</b> Tamper proof
	<b>70MH</b> 70w PSMH, medium base	<b>MT</b> Multi-Tap 120/208/240/277V	<b>WHT</b> White	<b>PC<sup>5</sup></b> Photocell
	<b>2PLC13-ELB</b> 2 13w CFL, G24q-1 base	<b>347</b> 347V	<b>SAL</b> Platinum	<b>F</b> Fusing
	<b>PLC26-ELB</b> 26w CFL, G24q-3 base	<b>U</b> 120-277V (induction)		<b>EMQ<sup>3</sup></b> Emergency quartz Restrike (socket only)
	<b>GFO80/GFP80</b>			<b>EMQLP<sup>3</sup></b> EMQ lamp
	<b>100HPS</b> 100w HPS, medium base			<b>LP<sup>4</sup></b> Lamp included
	<b>150HPS</b> 150w HPS, medium base			
	<b>100MH</b> 100w PSMH, medium base			
	<b>150P</b> 150w PSMH, medium base			
	<b>2PLC26</b> 2 26w CFL, G24d-3 base, mag.			
	<b>PLT42-ELB</b> 42w CFL, GX24q-4 base			
	<b>100I<sup>1</sup></b> 100w Induction (4067 delivered lumens)			
	<b>70I<sup>1</sup></b> 70w Induction (3300 delivered lumens)			

MOUNT
<b>TM</b> Trunnion mount
<b>QM</b> Machined & counter-balanced for 1/2" pendant, stem by others (not available for GFO40 Series)
<b>PCB</b> Pendant

- 1 Contains Sylvania Icetron® system, 4100K, Available in GFP80 model only, 100,000hr lamp life
- 2 50Hz, 220/240V available (consult factory)
- 3 Not available on induction
- 4 Lamp included for induction
- 5 Specify voltage

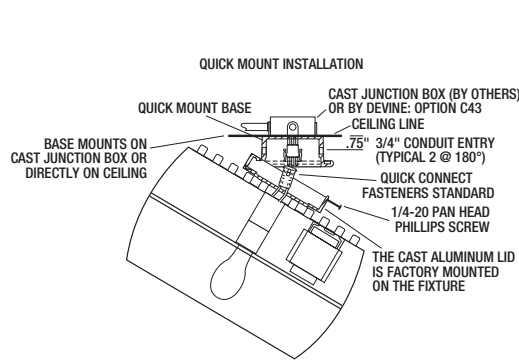
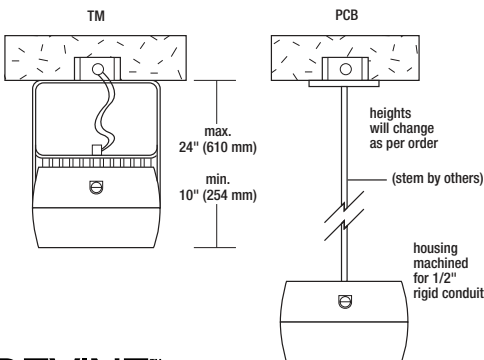

	A	B
<b>GFO40</b>	10"	7"
	254 mm	178 mm
<b>GFP80</b>	14 1/4"	8 1/2"
	362 mm	216 mm